

X-PRO D200 liquid screed machine - Vibrating strainer

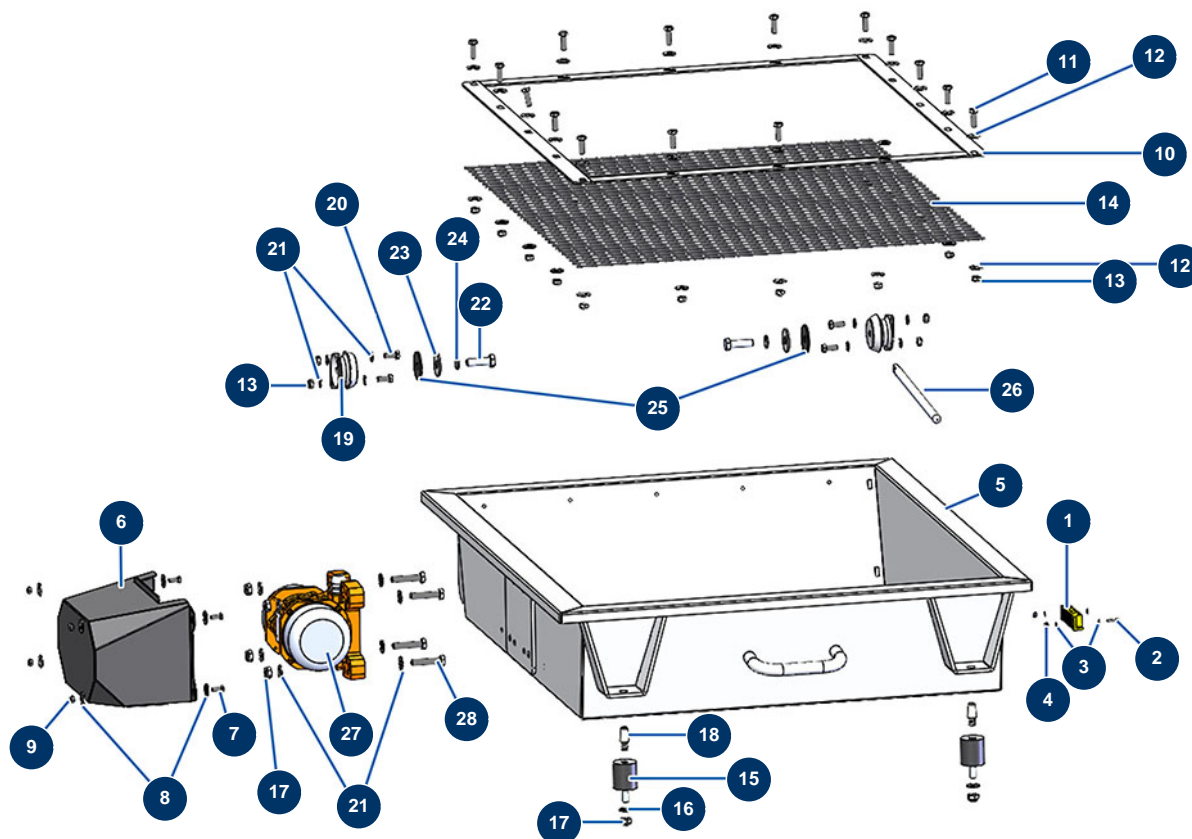

Détails des pièces

Pos.	Référence	Désignation
1	12980	Hopper and mixer safety grid sensor - C.P 60
2	90137	4 x 16 cylindrical head screw
3	30267	ø 4 inox narrow washer
4	30266	M 4 nylstop nut
5	C23020	5
6	C22874	6
7	12069	THEF 6 x 16 screw
8	70087	ø 6 inox narrow washer
9	14217	M 6 nylstop inox nut
10	C23022	
11	30205	THEF 8 x 30 screw
12	30292	ø 8 inox large washer
12	30292	ø 8 inox large washer

Pos.	Référence	Désignation
13	13980	M 8 nylstop inox nut
13	13980	M 8 nylstop inox nut
14	C23249	
15	20172	Silentbloc ø 40 x 45 M-F10
16	30280	ø 10 inox narrow washer
17	13981	M 10 nylstop inox nut
17	13981	M 10 nylstop inox nut
18	20052	Conical pin 24 x 12/16 mm M10
19	20230	Silentbloc for X-PRO D motor plate + sieve
20	30273	THEF 8 x 20 screw
21	30256	ø 8 inox narrow washer
21	30256	ø 8 inox narrow washer
22	12928	THEF 12 x 40 screw
23	30281	ø 12 inox narrow washer
24	12462	Grower washer ø 12
25	20714	25
26	20705	26
27	20075	12VDC MVE200/3N vibrator
28	30260	THEF 10 x 50 screw