

X-PRO D60 V2 spraying machine - Mixer cylinder

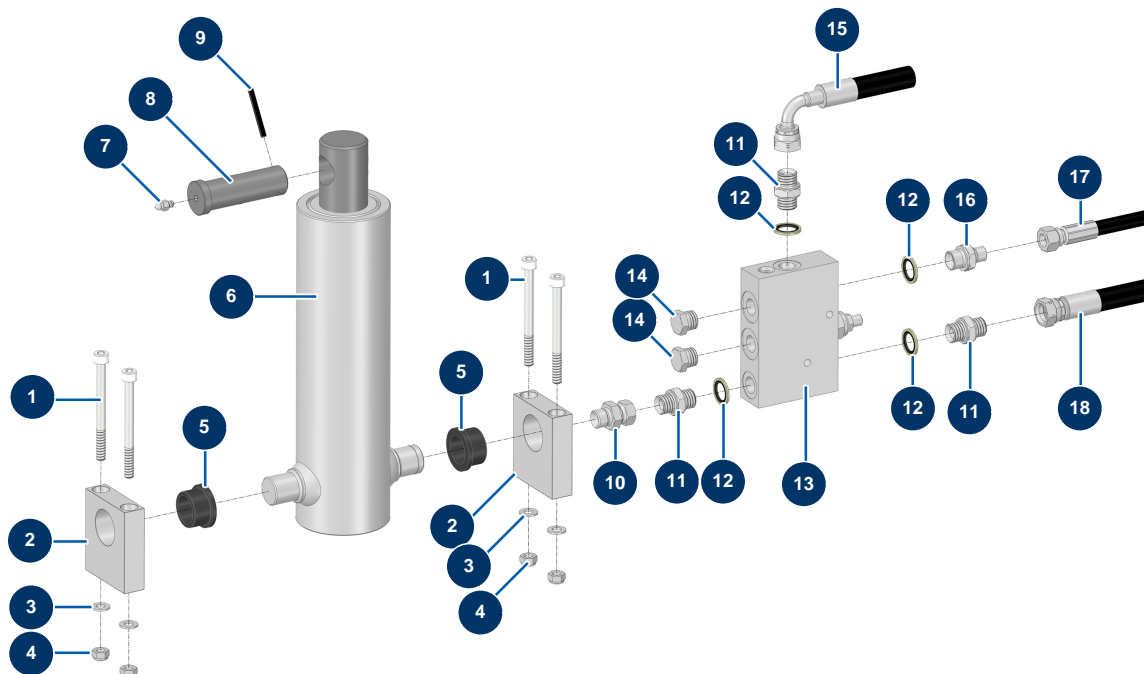

Détails des pièces

Pos.	Référence	Désignation
1	14152	8 x 90 cylindrical head screw
1	14152	8 x 90 cylindrical head screw
2	M20015	Hopper cylinder support CP 60 & 80
2	M20015	Hopper cylinder support CP 60 & 80
3	30256	ø 8 inox narrow washer
3	30256	ø 8 inox narrow washer
4	13980	M 8 nylstop inox nut
4	13980	M 8 nylstop inox nut
5	14129	Bearing with flange 25/32 x 20 - CP 60 & 80
5	14129	Bearing with flange 25/32 x 20 - CP 60 & 80
6	12307	Mixer telescopic cylinder - C.P 60
7	60012	M6 straight lubricator
8	M10251	Cylinder axle - CP 60

Pos.	Référence	Désignation
9	12474	Cylinder axis elastic pin - CP 60
10	14287	16/150 MaleD x 3/8" FemaleC - CP 60 high-pressure nipple
11	90698	3/8" MaleD x 3/8" MaleD high-pressure nipple
11	90698	3/8" MaleD x 3/8" MaleD high-pressure nipple
11	90698	3/8" MaleD x 3/8" MaleD high-pressure nipple
12	91031	Steel gasket for hollow screw with 3/8 lip
12	91031	Steel gasket for hollow screw with 3/8 lip
12	91031	Steel gasket for hollow screw with 3/8 lip
12	91031	Steel gasket for hollow screw with 3/8 lip
13	15028	
14	90238	3/8" low-pressure male plug
14	90238	3/8" low-pressure male plug
15	15390	
16	90704	1/4" MaleD x 3/8" MaleD high-pressure nipple
17	15386	
18	15392	